

# **AXIS 1650 User's Manual**

## **The Network Print Server for Canon Printers and Multifunctional Products**

\* Including support for the host-based printing methods  
Canon Advanced Printing Technology  
Canon Advanced Raster Printing System  
and other printer types such as Canon BubbleJet

# Safety Notices

Take some time to read through the safety notices before installing the print server. Please observe all safety markings and instructions when using this product.

## Important:

Observe "Important:" in the text to avoid operational impairment. Do not proceed until you have fully understood the implications.

## Electromagnetic Compatibility (EMC)

### USA

This equipment has been tested and found to comply with the limits for a Class B digital device, pursuant to Part 15 of the FCC Rules. These limits are designed to provide reasonable protection against harmful interference in a residential installation. This equipment generates, uses and can radiate radio frequency energy and, if not installed and used in accordance with the instructions, may cause harmful interference to radio communications. However, there is no guarantee that interference will not occur in a particular installation. If this equipment does cause harmful interference to radio or television reception, which can be determined by turning the equipment off and on, the user is encouraged to try to correct the interference by one or more of the following measures:

- reorient or relocate the receiving antenna
- increase the separation between the equipment and receiver
- connect the equipment into an outlet on a circuit different from that to which the receiver is connected
- consult the dealer or an experienced radio/TV technician for help. Shielded (STP) network cables must be used with this unit to ensure compliance with the class B limits.

### Europe

This digital equipment fulfils the requirements for radiated emission according to limit B of EN55022, and the requirements for immunity according to EN55024 residential, commercial, and light industry. Compliance is not valid for unshielded network cables.

### Japan

This is a class B product based on the standard of the Voluntary Control Council for Interference from Information Technology Equipment (VCCI). If this is used near a radio or television receiver in a domestic environment, it may cause radio interference. Install and use the equipment according to the instruction manual. Compliance is not valid for unshielded network cables.

### Australia

This electronic device meets the requirements of the Radio communications (Electromagnetic Compatibility) Standard 1998 AS/NZS 3548. Compliance is not valid for unshielded network cables.

## Liability

Every care has been taken in the preparation of this manual; if you detect any inaccuracies or omissions, please inform your local Axis office, which can be found on the cover of this document. Axis Communications AB cannot be held responsible for any technical or typographical errors and reserves the right to make changes to the product and manuals without prior notice. Axis Communications AB makes no warranty of any kind with regard to the material contained within this document, including, but not limited to, the implied warranties of merchantability and fitness for a particular purpose. Axis Communications AB shall not be liable nor responsible for incidental or consequential damages in connection with the furnishing, performance or use of this material.

## Axis' Trademarks

AXIS IP JumpStarter, AXIS CAPT Print Monitor.

## Other Trademark Acknowledgments

Adobe Acrobat Reader, Canon, Ethernet, Internet Explorer, Microsoft, NetScape, NetSpot Device Installer (NSDI), Windows, are registered trademarks of the respective holders.

## Patent information

Axis AB has intellectual property rights relating to technology embodied in the product that is described in this document. In particular, and without limitation, these intellectual property rights may include one or more of the patents listed at <http://www.axis.com/patent.htm> and one or more additional patents or pending patent applications in the US and other countries.

AXIS 1650 User's Manual

Revision 1.01

Part No: 22415

Date: August 2004

Copyright © Axis Communications AB, 2004

## Table of Contents

	About this Manual .....	5
	About Axis .....	5
	Support Services .....	6
Section 1	Product Overview .....	7
	Package Contents .....	7
Section 2	Print Server Installation .....	11
	1. Connect the Hardware .....	11
	2. Set the IP Address .....	13
	Set an IP Address with NetSpot Device Installer software .....	18
	IP Address Host Names .....	21
Section 3	Windows Installation .....	22
	Installing Printer Ports using AXIS CAPT Print Monitor .....	22
	Using AXIS CAPT Print Monitor in Windows 2000, XP and Server 2003 .....	23
	Using AXIS CAPT Print Monitor in Windows 98 and Me .....	29
	Using the Standard TCP/IP Port in Windows 2000/XP/2003 .....	32
Section 4	Print Server Management and Configuration .....	35
	Configuration Overview .....	35
	Print Server Management from the Embedded Web Pages .....	36
	Accessing the Embedded Web Pages .....	37
	Available Services from the User Mode .....	38
	Available Services from the Admin Mode .....	40
	Print Server Management Using FTP .....	51
	Print Server Management Using SNMP .....	53
Section 5	The Test Button .....	54
Section 6	Upgrading the Firmware .....	55
Appendix A	Enabling Unicast Network Communication .....	58
Appendix B	Internet Connection Firewall in Windows XP SP2 .....	62
Index	.....	68

## Preface

Thank you for purchasing the AXIS 1650. This product has been developed to connect your printer anywhere in your network, allowing all network users access to shared printer resources.

## About this Manual

This manual is applicable for the AXIS 1650 print server with firmware version **1.00** or later, providing introductory information as well as detailed instructions on how to set up and manage the print server in various network environments. It is intended for everyone involved in installing and managing the print server. To fully benefit from this manual, you should be familiar with basic networking principles.

These instructions are based on the settings in a **new** and **unconfigured** print server. To reload the default parameters, you can perform a Factory Default, which will restore all default settings. See *The Test Button*, on page 54.

## About Axis

Axis increases the value of network solutions. The company is an innovative market leader in network video and print servers. Axis' products and solutions are focused on applications such as security surveillance, remote monitoring and document management. The products are based on in-house developed chip technology, which is also sold to third parties.

Axis was founded in 1984 and is listed on the Stockholmsbörsen (XSSE:AXIS). Axis operates globally with offices in 14 countries and in cooperation with distributors, system integrators and OEM partners in 70 countries. Markets outside Sweden account for more than 95 % of sales. Information about Axis can be found at [www.axis.com](http://www.axis.com)

## Support Services

Should you require any technical assistance, please contact your Axis reseller. If your questions cannot be answered immediately, your Axis reseller will forward your queries through the appropriate channels to ensure a rapid response.

If you are connected to the Internet, you can:

- Download user documentation and firmware updates
- Find answers to previously resolved problems in the FAQ database. Search by product, category or phrase
- Report problems to Axis support staff by logging in to your private support area
- Visit the Axis support Web: [www.axis.com/techsup](http://www.axis.com/techsup)

# Section 1 Product Overview

## Package Contents

<i>Hardware</i>	<i>Model</i>	<i>Model/ Part Number</i>
Network Print Server	AXIS 1650	0214-001- XX With firmware version 1.00 or higher
Adhesive Holder & Clip	ACC AXIS CLIPS K	20119
USB Cable	70 cm, 28 inches USB cable supports USB Low-Speed and Full-Speed. Hi-Speed is not supported.	20208
<i>Power Adapter</i>	<i>Model</i>	<i>PS-H Part No.</i>
	Australia	19111
	Europe	19108
	UK	19109
	Japan	19110
	USA (120V)	19110
	USA (230V)	19108
Network cable	RJ 45 Shielded CAT5 0.5M	16283
CD	AXIS 1650 CD	rev.1.0 or higher
Printed Material	AXIS 1650 Quick Installation Guide	rev.1.0 or higher
	WARRANTY AXIS SERVERS 1YR	21681
<i>Optional accessories (not included in package)</i>	<i>Description</i>	<i>Part Number</i>
Cables	Parallel Printer Cable	13360
	Centronics to Mini Centronics Cable	16453

## The AXIS 1650 Network Print Server

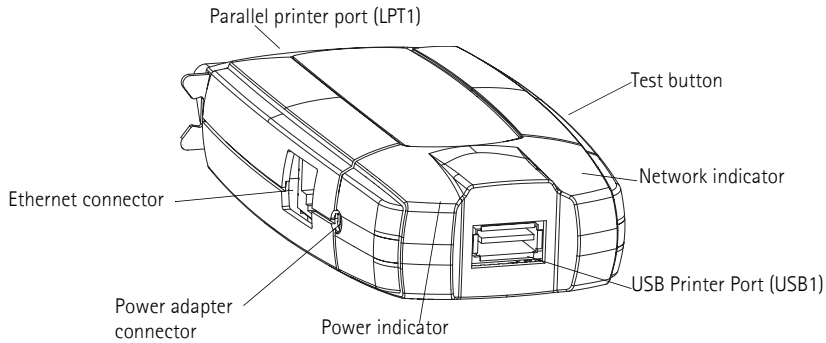

### Supported Printers

AXIS 1650 is developed to network Canon printers and multifunctional products. AXIS 1650 supports host-based printing methods such as Canon Advanced Printing Technology, Canon Advanced Raster Printing System and other printer types such as Canon BubbleJet.

**IMPORTANT:** Printers from other manufacturers than Canon are not supported.

### Supported Environments

The AXIS 1650 supports printing over **TCP/IP** from the following clients:

- Windows 98
- Windows Me
- Windows 2000
- Windows XP
- Windows Server 2003

## Installation and Integration

The installation of the AXIS 1650 and its integration into the network is performed using one of these software combinations:

- **AXIS IP JumpStarter** (for IP setting) and then **AXIS CAPT Print Monitor** (for printer installation)
- **Canon NetSpot Device Installer** (for IP setting) and then **AXIS CAPT Print Monitor** (for printer installation)
- AXIS IP JumpStarter and AXIS CAPT Print Monitor are available free of charge from the AXIS 1650 CD and on [www.axis.com](http://www.axis.com).
- NetSpot Device Installer is available on [www.canon.com](http://www.canon.com)

## Configuration and Management

Configuration and management of AXIS 1650 is performed using the TCP/IP protocol. The main method is using a **Standard Web browser**, See "Print Server Management from the Embedded Web Pages" on page 36.

## Printing Protocol: TCP/IP

### Speed

The AXIS ETRAX chip has been specifically designed for LAN products and benefits users with a faster throughput than a direct PC-to-printer connection. With a sustained data throughput of over 1 Mbytes per second (100baseTX) the AXIS 1650 is fast. ECP high-speed communication is supported.

**Security:** You can assign a password that restricts unauthorized configuration of the AXIS 1650.

**Monitoring:** The AXIS 1650 embedded Web pages allow you to continuously monitor printer status. Additionally, the AXIS 1650 supports SNMP for remote monitoring.

**Future proof:** You can upgrade the AXIS 1650 Flash memory over the network. This allows you to quickly update and enhance the operational features of your AXIS 1650 when new print server software becomes available.

### Printer Ports

- One Low and -Full speed USB 1.1 port that also works with USB 2.0. Hi-Speed is not supported.
- One high-speed IEEE 1284 compatible parallel port that plugs directly into the printer's parallel port.

AXIS 1650 is featured with two ports for ease of integration with most Canon printers. There is however no support for handling two connected printers simultaneously.

## Section 2 Print Server Installation

Follow these steps to install and configure your AXIS 1650:

1. *Connect the Hardware*, on page 11
2. *Set the IP Address*, on page 13
3. *Windows Installation*, on page 22

### 1. Connect the Hardware

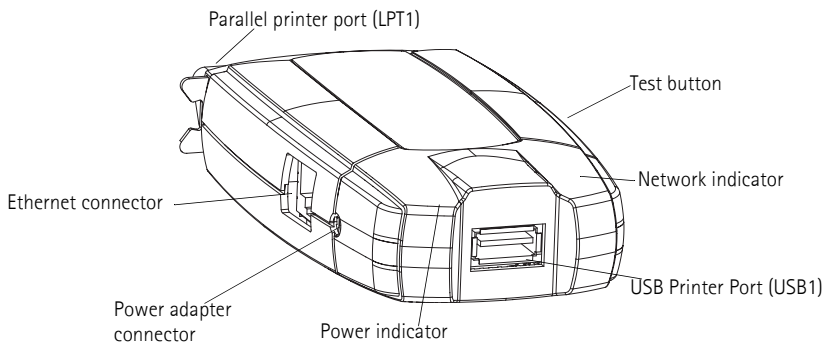

### Backside label of print server

The print server's Mac/Ethernet address is based on its serial number (S/N).

*Example: If the print server's serial number is 00408c181cf0 the Ethernet/Mac address will be 00-40-8c-18-1c-f0*



1. Make sure that your printer is switched off and that the print server's power adapter is disconnected.
2. Locate the **serial number**, found on the underside label of the print server, and write it down. You will need this number to configure the print server.
3. Either connect the printer to the USB port using the USB cable, or connect the printer directly to the LPT port or use a printer cable.

AXIS 1650 is featured with two ports for ease of integration with most Canon printers. There is however no support for handling two connected printers simultaneously.

4. Connect the print server to the network using a shielded twisted pair (category 5) RJ45 cable, 10baseT or 100baseTX.
5. Switch on the printer and make sure it is ready for use.
6. Connect the Power Adapter to the print server. The power indicator will light up. When the network indicator starts to flash, the print server is correctly connected to the network.
7. Optionally, you can mount the print server e.g. on the back of the printer or on a wall, using the supplied clips and holder.

Adhesive Clip



Fasten to print server by peeling off adhesive tape.

Adhesive Holder



Fasten to mounting surface by peeling off adhesive tape.

## 2. Set the IP Address

- Before setting the IP address, make a note of the print server's serial number (S/N), located on its backside label. See *Backside label of print server*, on page 11.
- You should obtain an unused IP address from your network administrator.

<i>Method</i>	<i>Platform</i>	<i>Comment</i>
AXIS IP JumpStarter software	Windows	Axis software that allows you to find print servers in your network and assign an IP address to them.  See <i>Set a Static IP Address using AXIS IP JumpStarter</i> , on page 14
Arp/Ping	Windows	See <i>Set a Static IP Address using ARP in Windows 98/Me/2000/XP/2003</i> , on page 16
	Unix/Linux	See <i>Set a Static IP Address using ARP in UNIX</i> , on page 17
Canon's NetSpot Device Installer software	Windows	Canon software that allows you to find print servers in your network and assign an IP address to them.  See <i>Set the IP address using NetSpot Device Installer</i> , on page 19

It is not possible to obtain a dynamic IP address using DHCP, since DHCP is disabled by default in AXIS 1650. To enable DHCP in the print server, see *DHCP Enabled*, on page 46. You can, however, obtain a DHCP address for the print server via AXIS IPJumpStarter or NetSpot Device Installer. If you choose to obtain a DHCP address for the print server from these programs, the DHCP function will be enabled in the print server.

## Set a Static IP Address using AXIS IP JumpStarter

AXIS IP JumpStarter is an application that helps you to locate your Axis print server on the network and assign an IP address to it.

1. Install AXIS IP JumpStarter, it is available on the AXIS 1650 CD and on [www.axis.com](http://www.axis.com)
2. Select a print server from the serial number list. All AXIS 1650 appear with the default IP address 192.168.0.90. If you are installing several AXIS 1650, check the Serial Number to locate a specific print server.

The screenshot shows the AXIS IP JumpStarter application window. The main window displays a table of print servers with columns for Serial Number, Name, Model, IP Address, and IP Setting Method. The 'Set IP Address' dialog box is open, showing the 'Specify an IP address (static)' option selected. The dialog box contains fields for Serial Number, IP Address, Subnet Mask, and Default Gateway. A text box at the bottom of the dialog box reads: 'Note: If a field is left blank the server's current value will remain unchanged.' Buttons for 'OK', 'Cancel', and 'Help' are visible at the bottom of the dialog box.

Serial Number	Name	Model	IP Address	IP Setting Method
not in list?				
00408C181636	AXIS181636	AXIS 560+	10.13.4.223	dynamic
00408C3A459E	AXIS3A459E	AXIS 5600+	10.13.6.128	dynamic
00408C3E7040	AXIS3E7040	AXIS 1650	192.168.0.90	dynamic
00408C363300	AXIS363300	AXIS 5470e	10.13.6.27	dynamic
00408C1813DF	AXIS1813DF	AXIS 5800 Mobile	10.13.6.124	static
00408C181312	AXIS181312	AXIS 5800+ Mobile	10.13.3.131	static
00408C557D9C	AXIS557D9C	AXIS 5400+	10.13.6.119	dynamic
00408C5AA9F4	AXIS5AA9F4	AXIS 5600+	10.13.6.116	dynamic
00408C3E8446	AXIS3E8446	AXIS 5470e	10.13.6.25	dynamic
00408C181642	AXIS181642	AXIS 5900	10.13.3.21	static

Workstation IP Address: 10.13.4.192

Set IP Address dialog box:

Enter the serial number manually if the server is not found.  
 Serial Number: 00408c181cf0

Obtain an IP address automatically (dynamic)  
 Specify an IP address (static)

IP Address: 192 . 168 . 3 . 191  
 Subnet Mask: 255 . 255 . 255 . 0  
 Default Gateway: 192 . 168 . 3 . 191

Note: If a field is left blank the server's current value will remain unchanged.

Buttons: OK, Cancel, Help

Annotation: All AXIS 1650 have the default IP address 192.168.0.90. Change this default IP address to either a static IP address or to a DHCP address.

3. From the **Server** menu, select **Set IP Address**. The **Set IP Address** dialog appears.

4. Click the radio button that corresponds to your choice of IP setting method (static or dynamic using DHCP). When assigning a static IP address you also have to define the **Subnet Mask** and **Default Gateway**.
5. Click **OK** to save your settings.
6. You may be prompted to enter the server root password (by default set to <blank>), click **OK** and the print server will appear in the list with the assigned IP address.
7. To verify that you have access to the print server's Web pages, highlight the print server in the list and select **Server Home Page** from the **Server** menu.
8. You have now finished the procedure of setting the IP address. Continue to *Windows Installation*, on page 22.

## Set a Static IP Address using ARP in Windows 98/Me/2000/XP/2003

1. Open a Command Prompt and type:

```
arp -s <IP address> <Ethernet address>  
ping -l 479 <IP address>
```

*Example:*

```
arp -s 192.168.3.191 00-40-8c-18-1c-f0  
ping -l 479 192.168.3.191
```

2. If the host returns `Reply from 192.168.3.191 ...` or a similar message, the IP address has been set successfully.  
If the host returns `Request time out...` you need to reboot the print server and perform steps 1-2 above again. Rebooting the print server is done by disconnecting and then re-connecting the print server's power supply.
3. Access the print server's Web pages ( - See page 37), select **Admin | Network Settings | Detailed View | TCP/IP** and define the **Default Router** and **Subnet Mask**. Make sure **DHCP**, **BOOTP** and **RARP** are disabled.

You have now set the IP address of the print server. Continue with *Windows Installation*, on page 22.

### Note:

When you execute the ping command for the first time, you will experience a significantly longer response time than usual.

## Set a Static IP Address using ARP in UNIX

Follow the instructions below to set the IP address using ARP.

1. Type the following commands in the shell window:

```
arp -s <ip address> <Ethernet address> temp  
ping -s 479 <ip address>
```

*Example:*

```
arp -s 192.168.3.191 00:40:8c:18:1c:f0 temp  
ping -s 479 192.168.3.191
```

2. The host will return `192.168.3.191 is alive` or a similar message. This indicates that the address has been set and that the communication is established.
3. Access the print server's Web pages ( - See page 37), select **Admin | Network Settings | Detailed View | TCP/IP** and define the **Default Router** and **Subnet Mask**. Make sure **DHCP**, **BOOTP** and **RARP** are disabled.

### Notes:

- The ARP command varies between different UNIX systems. Some BSD type systems expect the host name and node address in reverse order.
- When you execute the `ping` command for the first time, you may experience a significantly longer response time than usual.

## Set an IP Address with NetSpot Device Installer software

NetSpot Device Installer is software from Canon that allows you to assign an IP address and manage Canon devices connected to your network. NetSpot Device Installer software is supplied on CD-ROM with your Canon printer and on [www.canon.com](http://www.canon.com)

Depending on the provided CD-ROM, NetSpot Device Installer may not be included. If this is the case, please download NetSpot Device Installer from [www.canon.com](http://www.canon.com)

### Install NetSpot Device Installer

1. In Windows 2000/XP, log on as an Administrator before installing. Insert the CD-ROM supplied with your Canon printer into the CD-ROM drive of your computer.
2. In Windows Explorer, double-click the CD-ROM drive icon.
3. Double-click **NetSpot\_Device\_Installer => Windows => nsdisetup.exe**
4. A license agreement will be shown in the window. Check the contents and click **Yes**.
5. Specify the program destination folder and click **OK**. The installation will launch.

If you check "Add to Start menu", you can add NetSpot Device Installer to your Window's Start menu.

6. When the installation is finished, click **OK**. You can now start the program, see *Set the IP address using NetSpot Device Installer*, on page 19.

### Set the IP address using NetSpot Device Installer

Follow these instructions to set the IP address using NetSpot Device Installer:

1. Start the program. The main window will open. After a while a list of devices detected on the network will be displayed.
2. Select the AXIS 1650 that displays the unit's MAC address and default IP address **192.168.0.90**

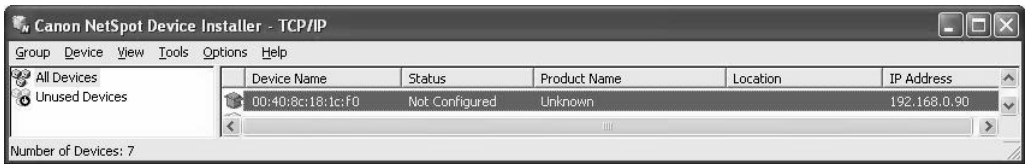

The MAC address is based on the Serial Number (S/N) of your AXIS 1650 and is printed on the underside label of the print server.

3. From the Device menu, select Initial Settings.

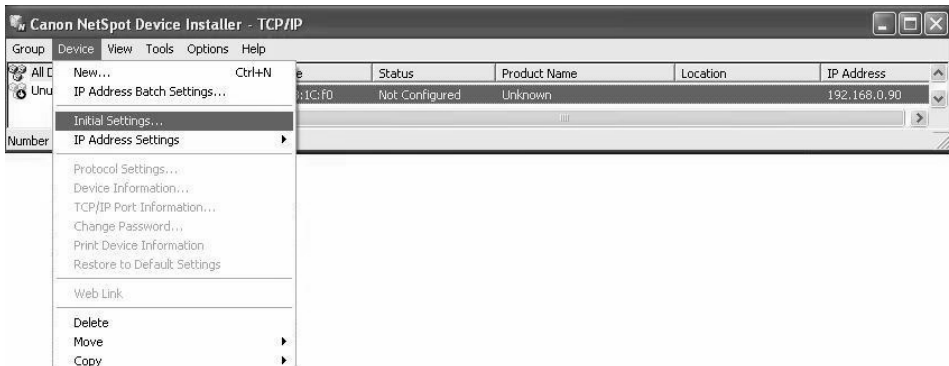

4. From the Initial Settings dialogue box, select the AXIS 1650 print server from the Product Type drop-down list and click Next.

- Next, configure the TCP/IP protocol:

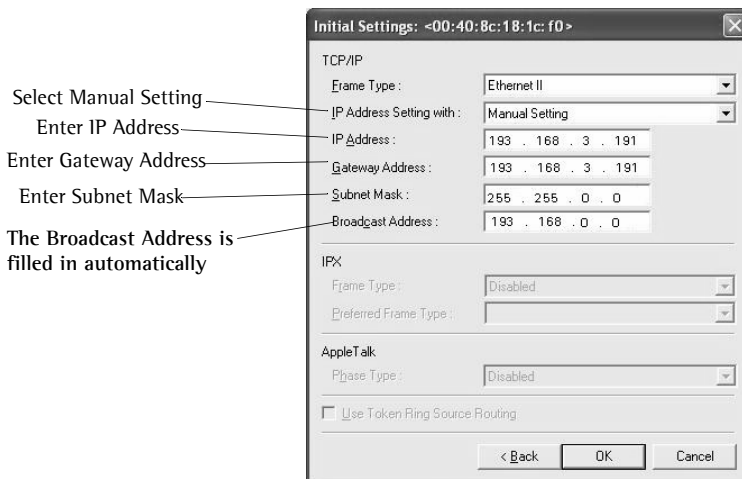

- After you have finished the configuration, click **OK**.

If you get a message reading "Resetting device", click **OK**.

- Click **OK**. Your printer's protocol configuration is now finished and your AXIS 1650 has received an IP address. Continue to *Windows Installation*, on page 22.

## IP Address Host Names

If you are using host names, you can map a unique host name to the IP address. Refer to your system manuals or to your network administrator for instructions on how to perform name mapping on your system.

### Notes

- You need to know the Ethernet address of your AXIS 1650 to perform the installation. The Ethernet address is based on the serial number of your AXIS 1650. For example, an AXIS 1650 with the serial number of 00408C181CF0, will have the corresponding Ethernet address of 00 40 8C 18 1C F0. The serial number is located on a label on the backside of the print server.
- DO NOT use the IP addresses shown in the following examples when installing the AXIS 1650.
- ARP/Ping operates on single network segments only, i.e. **it cannot be used over routers**.
- The default host name of the print server is 'AXIS' followed by the last 6 digits in the serial number. e.g. AXIS181636. The host name is changed in the **Print server name** field in **Admin | General Settings**.
- The host name limitations conclude that if you want to register the same host name at a WINS server and a DDNS server, the host name should be no longer than 15 characters and it should only contain the characters 'A-Z', 'a-z', '0-9' and '-'.
- Refer to your system manuals or to your network administrator for instructions on how host name resolutions are performed on your system.
- At least one WINS server IP address must be included in the DHCP scope if you are using WINS. Immediately after the IP address has been received, the AXIS 1650 registers its host name and IP address on the WINS server.
- If the host name has not been mapped to the IP address, you can still perform the following instructions to download the IP address. In this case, simply replace the host name entry with the IP address wherever required.

## Section 3 Windows Installation

### Installing Printer Ports using AXIS CAPT Print Monitor

AXIS CAPT Print Monitor is a Windows component that has been developed for network printing. AXIS CAPT Print Monitor is the recommended tool for Canon printers, including CAPT, Canon Advanced Raster Printing System and BubbleJet.

AXIS CAPT Print Monitor allows your AXIS 1650 to be connected in the same simple fashion as a local printer port and once installed, it is automatically initialized upon system start-up. AXIS CAPT Print Monitor needs to be installed on each workstation for peer-to-peer printing.

Refer to the instructions relevant to your network on how to install a printer using AXIS CAPT Print Monitor:

- *Print Server Installation using AXIS CAPT Print Monitor in Windows 2000, XP and Server 2003 on page 23*
- *Print Server Installation using AXIS CAPT Print Monitor in Windows 98 and Me on page 29*

See also *Print Server Installation using the Standard TCP/IP Port in Windows 2000/XP/2003*, on page 32.

## Print Server Installation using AXIS CAPT Print Monitor in Windows 2000, XP and Server 2003

1. Install the AXIS CAPT Print Monitor on your workstation. The software is available on the AXIS 1650 CD and on [www.axis.com](http://www.axis.com)
2. Launch the software installation and click **Next**.



3. Read the License Agreement and click **Yes** if you accept the terms.



4. Leave this check-box unchecked\* and click Next.

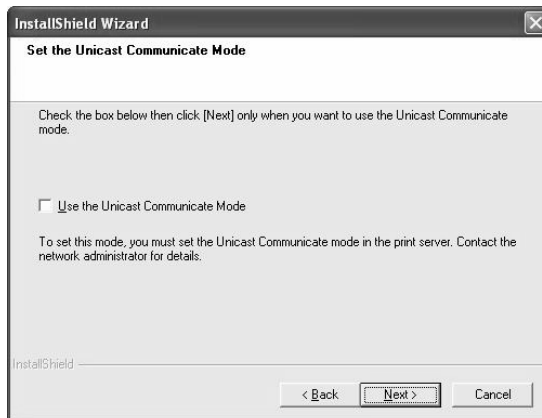

\* If you want to disable broadcast status updates and enable unicast, see *Enabling Unicast Network Communication*, on page 58

**Windows XP/Server 2003 only:**

Make sure the **Allow this application to process incoming network printer information on the local subnet** checkbox is checked.

Must be checked!



In Windows XP SP 2, UDP port 10260 must be open in the Internet Connection Firewall when using Broadcast communication. UDP port 10260 is opened automatically in the Internet Connection Firewall when Windows XP SP2 is installed, if **Allow this application to process incoming network printer information on the local subnet** is checked.

5. Click **Finish** to finish the installation.



6. **Windows XP/Server 2003:**

Go to **Start | Printers and Faxes** and click the **Add a Printer** icon to start the Add Printer Wizard. (Windows XP Home Edition: **Start | Control Panel | Printers and Faxes | Add a Printer**). Click **Next**.

**Windows 2000:**

Go to **Start | Settings | Printers and** click the **Add Printer** icon to start the Add Printer Wizard. Click **Next**.



7. Select **Local Printer attached to this computer**. Make sure the **Automatically detect and install my Plug and Play printer** check box is not checked. Click **Next**.

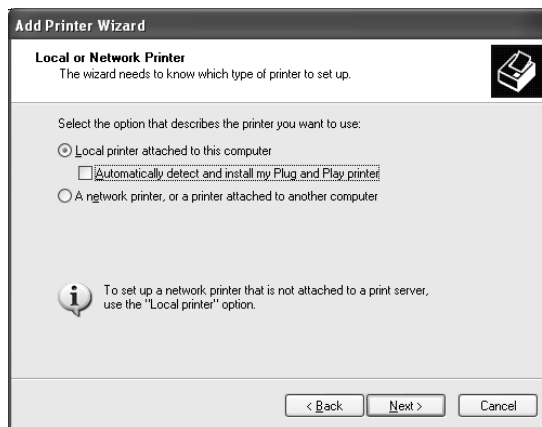

8. Click the **Create a new port** radio-button and select **AXIS CAPT Port\***. Click **Next**.

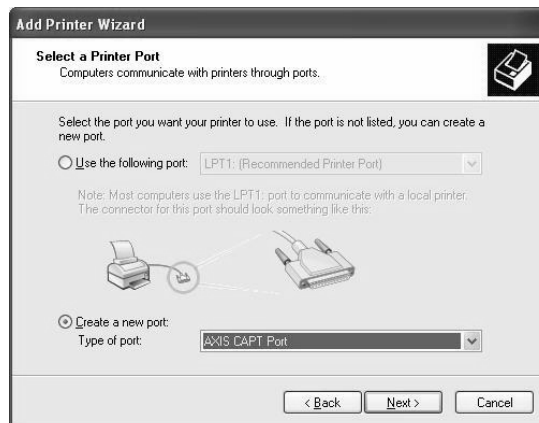

\* AXIS CAPT Port is used for all Canon printers, including CAPT, Canon Advanced Raster Printing System and BubbleJet.

- The AXIS CAPT Port pop-up window will appear. Select your AXIS 1650 from the Available network printers list and click OK.

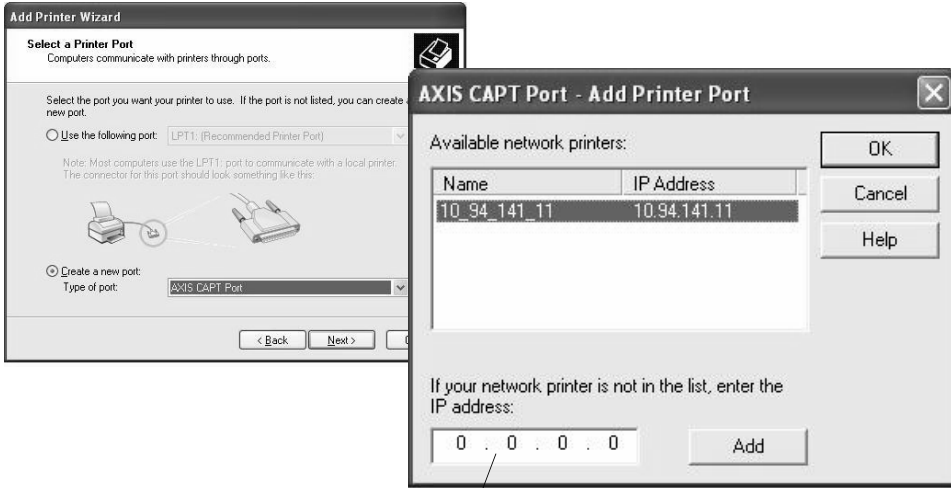

If your AXIS 1650 doesn't appear in the Available network printers list, enter its IP address and click Add.

- Select **Manufacturer and Printer** from the driver list. Click **Next**.
- Choose whether you want to keep the existing driver or to replace it. If you already have the printer's driver installed, you will be asked whether to keep it or to replace it.
- Click **Next**. Supply a name for the printer and choose whether you want to make it your default printer. Click **Next**.

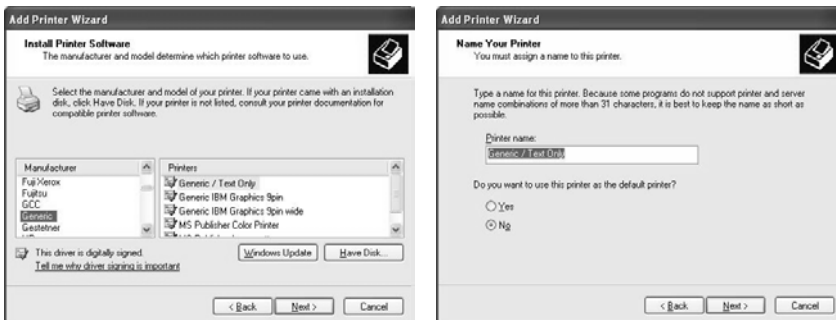

13. Choose whether you want to share the printer with other network users, print a test page, etc. Select the appropriate radio button and click **Next** and **Finish**.



14. Print a test page to verify. You have now completed the installation.

## Print Server Installation using AXIS CAPT Print Monitor in Windows 98 and Me

Follow the procedure below to install TCP/IP Ports from a Windows 98/Me workstation:

1. Install the AXIS CAPT Print Monitor on your workstation. The software is available on the AXIS 1650 CD and on [www.axis.com](http://www.axis.com)
2. Launch the software installation and click **Next**.



3. Read the License Agreement and click **Yes** if you accept the terms.

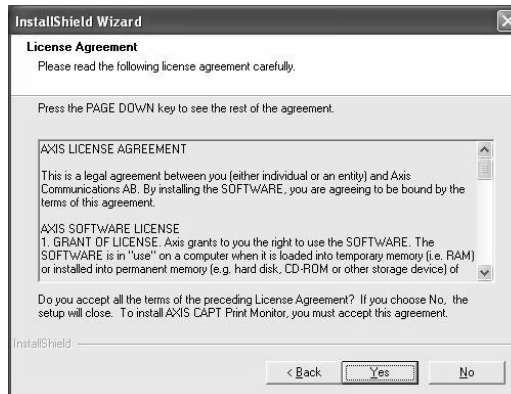

4. Leave this check-box unchecked\* and click **Next**.  
(\*If you want to disable broadcast status updates and enable unicast, See *Enabling Unicast Network Communication* on page 58 for instructions.)



5. Click **Finish** to finish the installation.



6. Select **Settings | Printers** from the **Start** menu and double-click the **Add Printer** icon to start the Add Printer Wizard.
7. Select **Local Printer**, as the AXIS 1650 emulates a local printer port and click **Next>**

8. Choose an appropriate printer driver for your printer.

If the desired driver appears in the manufacturer and models list dialog, highlight your selection and click **Next>**.

If the desired printer driver is not available, click the **Have Disk...** button. Insert the printer driver CD that was provided with your printer, select the CD drive and click **OK**.

9. Select the desired printer driver from the CD and click **Next>**

10. Select the port you wish to use and click **OK**.

- The ports will appear in the format <name>. , where <name> is, by default AXIS followed by the last six digits of the print server's serial number  
*Example: AXIS560B35.*
- If you wish to install a remote TCP/IP port (i.e. if the TCP/IP port does not appear in the list), select the **LPT1** port. Continue with steps 11 and 12 and then follow the **Remote Printer Port** instructions below.

11. Enter a descriptive name for your printer and click **Next>**

12. Click the checkbox if you want to print a test page and click **Finish**.

### Remote Printer Port

1. The printer you defined above is now displayed in the printers folder. Right-click the printer object and select **Properties** from the menu.
2. Click the **Details** tab and click **Add Port...** to display the available print server monitors.
3. Click **Other**, select **AXIS CAPT Port** and click **OK**.

\* AXIS CAPT Port is used for all Canon printers, including CAPT, Canon Advanced Raster Printing System and BubbleJet.

4. Enter the IP address / host name of your print server. Click **Add**.
5. The port will be added to the list and highlighted. Click **OK** to return to the printer ports dialog and click **Close**.

## Print Server Installation using the Standard TCP/IP Port in Windows 2000/XP/2003

Follow the instructions below to use the Windows Standard TCP/IP Port to add a network printer in Windows 2000/ Windows XP/2003.

### Windows XP/ Server 2003:

1. Go to **Start | (Settings) | Printers and Faxes** and click the **Add a Printer** icon to start the **Add Printer Wizard**. Click **Next**.

### Windows 2000:

1. Go to **Start | Settings | Printers** and click the **Add Printer** icon to start the **Add Printer Wizard**. Click **Next**.
2. Select **Local Printer attached to this computer** and make sure the **Automatically detect and install my Plug and Play printer** check box is not checked. Click **Next**.

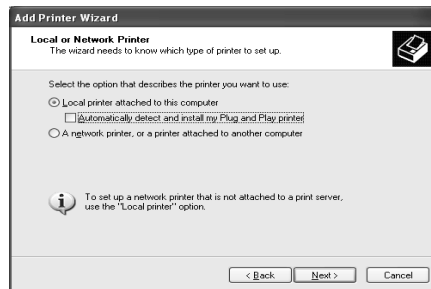

3. Click the **Create a new port** radio button and select **Standard TCP/IP Port** from the list. Click **Next** and the **Add Standard TCP/IP Printer Port Wizard** starts. Click **Next**.

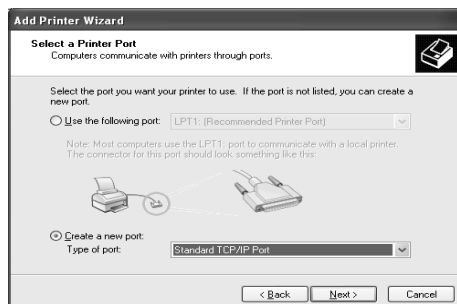

- In the **Printer Name or IP Address** field, enter the IP address of the print server (Example: 192.168.3.191) The **Port Name** field will be filled in automatically. Click **Next**.

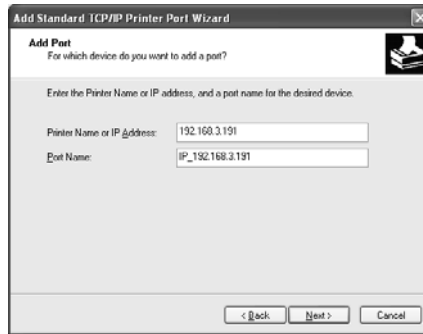

- Select **Manufacturer and Printer** from the lists. Click **Next**.



- If you already have the printer's driver installed, you will be asked whether to keep it or to replace it. Click **Next**. Supply a name for the printer and choose whether you want to make it your default printer. Click **Next**.
- Choose whether you want to share the printer with other network users, print a test page, etc. Select the appropriate radio button and click **Next** and **Finish**.



8. Next, from your desktop, go to **Start | Printers (and Faxes)**. Highlight the installed printer and right-click, choose **Properties**, then **Ports | Configure Port**.

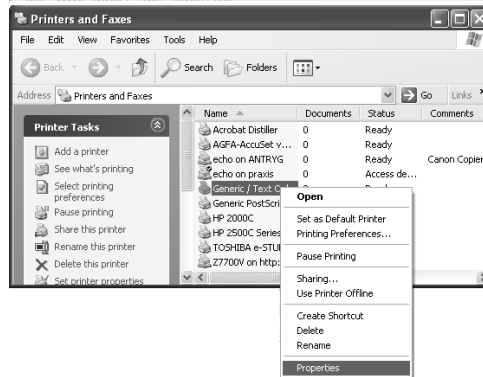

9. In the **LPR Settings - Queue Name** field, you will see the value "z". In the **Queue Name** field, type **USB1** or **LPT1**, depending on which printer port you are using. Click **OK** and then **Apply**.
10. Print a test page to verify. You have now finished the installation.

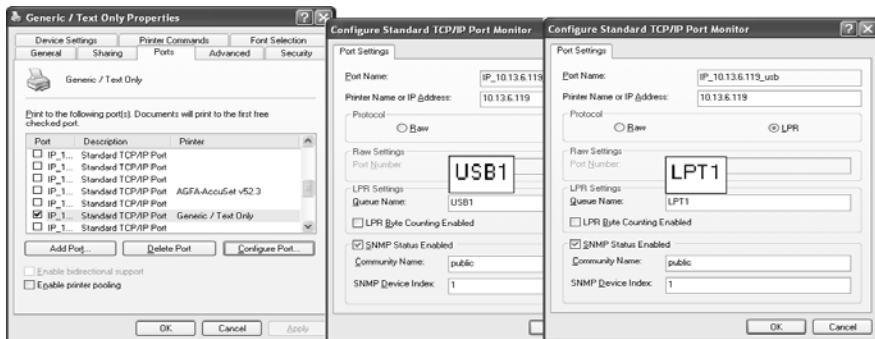

## Section 4      **Print Server Management and Configuration**

The management and configuration tools that are supported by the AXIS 1650 allow you to:

- Change print server parameters
- Receive extended information about print jobs
- Receive printer port status and monitor printers
- Reset the AXIS 1650

### **Configuration Overview**

The method you should use to manage and configure your AXIS 1650 is dictated by your TCP/IP network. The table below displays which method to use:

#### **Configuration/Management methods**

- Embedded Web Pages using a Web Browser - See page 36
- FTP - See page 51
- SNMP - See page 53

## Print Server Management from the Embedded Web Pages

All Axis print servers contain an embedded web server that can be accessed through a web browser. The embedded web server provides access to configuration and management pages for the print server and the connected printer, allowing you to perform e.g. these operations:

Once you have established the AXIS 1650 in the TCP/IP environment, as described in *2. Set the IP Address*, on page 13, you can access the AXIS 1650 Web pages from any standard Web browser. The AXIS 1650 embedded web pages are divided into two modes of operation:

- **User mode**  
In User mode, you have no rights to change any parameter settings, apart from the interface language. This mode is intended for regular users who are only interested in using the print server's interface for checking print jobs or viewing printer properties. If you want to change any other of the print server's settings, you must enter the Admin mode. See *Available Services from the User Mode*, on page 38.
- **Admin mode**  
When in Admin mode, you have access to all the print server's parameters and you can change them to your liking. This mode is intended for network administrators and can be password protected to prevent unauthorized changing of parameters. See *Available Services from the Admin Mode*, on page 40.



## Available Services from the User Mode

The following services are available from the User mode. A link to [www.axis.com](http://www.axis.com) is available from this mode.

Most settings displayed in the User mode are modified from the **Admin** mode!

### Printer Overview

The Printer Overview page contains a section that allows you to view the general parameter setting of the AXIS 1650 and the connected printer.

By clicking the printer icon a printer page opens, allowing you to view the status and the supported capabilities of the connected printer. The extent of this information depends on the printer model. From the printer page, you can also print a test page to the printer.



It is only possible to print a test page to Canon printers that support printing standard ascii characters. For Canon printers supporting Canon Advanced Printing Technology and Canon Advanced Raster Printing System, it is not possible to print a test page.

Underneath the printer icon is a colored symbol that indicates the status of the printer:

- **green** indicates that the printer is ready for printing
- **yellow** indicates warning
- **red** indicates error

### Print Server Name

This name identifies the print server to the users. The default name is AXISXXXXXX, where XXXXXX are the last six digits of the print server's serial number.

### System Location

This parameter displays where the print server is physically located, helping you to find the printer to which you have sent your print jobs.

## Serial Number

Every Axis device is uniquely identified by its serial number. The serial number is found on the under side label of your print server.

## Language

English and Japanese is supported in the print server's web interface. Change the language by clicking the **Change** button.

## Printer Status

This page displays the status and capabilities of the printer that is connected to the printer port. The capabilities include Detailed Status, Manufacturer, Command Sets, Capabilities, etc. The **Network Names** button to display a list of names that the printer is identified with in each supported network environment

## Print Jobs

From the Print Jobs page you can view Printer Usage that displays the accumulated usage of the printer connected to your print server. You can also view a log of the 32 latest print jobs that includes the user name, the document name, number of pages and the time when the document was printed.

- **Printer** - displays the printer model.
- **Port** - displays the printer port to which the printer is connected.
- **Status** - displays the status of the printer. The available status messages are ready, busy and off-line.
- **Printed Pages** - shows the number of pages that the printer has printed.
- The **Print Server Uptime** shows how much time that has elapsed since the last time the print server was restarted. The time when the document was printed is only available if connected to a time server.

## Notes:

- The Printer Usage log is erased each time the print server is restarted.
- You cannot receive information about the number of printed pages from all printer models.

## Help

The Help pages present basic information about the AXIS 1650 and the Web user interface.

## Available Services from the Admin Mode

The following services are available from the Admin mode. An additional link to [www.axis.com](http://www.axis.com) is available from this mode.

### This Print Server

This page contains a section that allows you to view and modify the general parameter setting of the AXIS 1650, including the print server name, the node address, the password and the base URL. Management operations, like restarting the AXIS 1650 and resetting its parameters to the software default settings, are also available.

All settings under **This Print Server** are modified in **General Settings => Change | General**

### Caution!

- All print server settings have *default values* that have been carefully selected by Axis. In most instances, there is no need to change these default values.
- All network configuration should involve the Network Administrator.

## General

### Print Server Name

This name identifies the print server to the users and will be part of the default name of the connected printer and printer queue name. The default name is AXISXXXXXX, where XXXXXX are the last six digits of the print server serial number.

*Example: If the serial number is 00 40 8c 18 16 36, the default print server name is AXIS181636.*

### System Name

This name identifies the network printer to the users.

*Default = <blank>*

**System Location**

This parameter allows you to specify where the network printer is physically located in your organization. This enables you to find the printer to which you have sent your print jobs.

*Default = <blank>*

**System Contact:**

Enter the name of e.g. the System Manager.

*Default = <blank>*

**System Contact Phone Nbr.:**

Enter the telephone number of e.g. the System Manager.

*Default = <blank>*

**System Comment:**

Enter comments regarding network printer.

*Default = <blank>*

**Language:**

Select the language to be displayed in the print server's embedded web pages.

- English
- Japanese

**Root Password:**

Enter a password in the field. Up to 15 alphanumeric characters can be entered.

*Default = <blank>*

**SNMP Enabled:**

- If **Yes** is selected, access using the SNMP protocol is permitted.
- If **No** is selected, any access using the SNMP protocol is rejected.

Default = Yes

### Community Name:

Specify the community name for SNMP. Up to 32 alphanumeric characters can be entered.

*Default = public*

### Restrictions

#### TCP Restriction Enabled

Users specified in the IP Address List are rejected or accepted, depending on TCP Restriction Mode, to send printjobs over the print server.

*Default = No*

#### TCP Restriction Mode

- **Accept** Users specified in [TCP Restriction Address List] are permitted to send printjobs over the print server.
- **Reject** Users specified in [TCP Restriction Address List] are rejected from sending printjobs over the print server.

Default = Accept

#### TCP Restriction IP Address List:

Users specified are rejected or accepted to print using the print server. IP addresses or ranges of IP addresses can be specified:

*Example IP addresses: 10.13.16.150, 10.13.16.151*

*Example IP address range: 10.13.16.160-0.13.16.170*

*Default = <blank>*

If your print server is connected to a CAPT 1.0 printer you will receive an error message stating Network Error if you are not allowed to print with this print server.

#### SNMP Restriction Enabled:

Users specified in **SNMP restriction IP address list** are rejected or accepted, depending on SNMP restriction mode. To specify, browse the settings for the device using SNMP.

*Default = No*

### SNMP Restriction Mode:

- **Accept** Only users specified in [SNMP restriction IP address list] are permitted to specify/browse the settings for the device using the SNMP protocol.
- **Reject** Only users specified in [SNMP restriction IP address list] are rejected from specifying/browsing the settings for the device using the SNMP protocol.

Default = Accept

### SNMP Restriction IP Address List:

Users specified here are rejected or accepted. To specify, browse the settings for the device using SNMP. IP addresses or ranges of IP addresses can be specified as follows:

*Example IP address: 10.13.6.150*

*Example IP address range: 10.13.16.160-10.13.16.170*

*Default = <blank>*

### SLP Restriction Enabled

Users specified in SLP restriction IP address list are rejected or accepted, depending on SLP restriction mode. To specify, browse the settings for the device using SLP.

*Default = blank*

### SLP Restriction Mode

- **Accept:** only users specified in [SLP restriction IP address list] are permitted to specify/browse the settings for the device using the SLP protocol.
- **Reject:** only users specified in [SLP restriction IP address list] are rejected from specifying/browsing the settings for the device using the SLP protocol.

*Default = Accept*

### SLP Restriction IP Address List

Users specified here are rejected or accepted. To specify, browse the settings for the device using SLP. IP addresses or ranges of IP addresses can be specified as follows:

*Example IP address: 10.13.6.150*

*Example IP address range: 10.13.16.160-10.13.16.170*

*Default = blank*

## Serial Number

Every Axis device is uniquely identified by its serial number. The serial number is found on the under side label of your print server. See *Print Server Installation*, on page 11.

## Parameter List

Displays a list of all parameters and their current settings.

## Restart

Restarts the print server. When the power LED lights constantly and the Network indicator starts flashing to indicate network activity, the print server is ready for use. New configuration settings will then become active.

All contact with the print server will be lost during the restart.

## Software Default

A Software Default will reset all print server parameters to their factory default settings except:

- Node address (NODE\_ADDR.)
- IP address (IP\_ADDR.)
- DHCP enabled or disabled (DHCP\_ENABLE.)

A **Software Default** differs from a **Factory Default**. A **Factory Default** is performed by pressing the *Test button*, located on the print server, in a specific sequence. See *The Test Button*, on page 54.

When the power LED lights constantly and the Network indicator starts flashing to indicate network activity, the print server is ready for use.

### Notes:

- All contact with the print server will be lost during the factory default.
- A dimmed printer denotes that no printer is connected to that port.

## Print Jobs

From the **Print Jobs** page you can view Printer Usage that displays the accumulated usage of the printer connected to your print server. You can also view a log of the 32 latest print jobs that includes the user name, the document name, number of pages and the time when the document was printed.

## Network Settings

From the **Network Settings** page you can set all parameters that control the network traffic to and from the AXIS 1650. You can enable or disable any of the supported network protocols and fine-tune the parameter settings.

## Detailed View

Click to enable or disable network protocols and to change network protocol parameters

### Frame Type

Frametype Ethernet II is used for network packages.

### LPD Banner Page Mode\*

Check the appropriate box to specify if the LPD banner page is to be printed.

- **OFF** disables the LPD banner page.
- **AUTO** prints the LPD banner page first or last depending on your operating system.
- **LAST** forces the printer to print the LPD banner page last independently of operating system.

*Default value = Off*

\*This parameter is not available for Canon printers supporting Canon Advanced Printing Technology or Canon Advanced Raster Printing System.

### DHCP Enabled

Select the appropriate radio button to enable DHCP (Dynamic Host Configuration Protocol). DHCP automatically downloads the IP address to each print server at startup. Depending on how your network has been configured, other Internet-related parameters such as the default router, subnet mask, etc. might also be set automatically. It is recommended that you verify the settings when the server has been restarted and then enter any missing parameters manually.  
*Default value = No (disabled)*

### BOOTP Enabled

Select the appropriate radio button to enable BOOTP (BOOTstrap Protocol). BOOTP downloads the IP address to each print server at startup. Depending on how your network has been configured, other Internet-related parameters such as the default router, subnet mask, etc. might also be set automatically. However, we recommend that you verify the settings when the server has been restarted and then enter any missing parameters manually.  
*Default value = No (disabled)*

### RARP Enabled

Select the appropriate radio button to enable RARP (Reverse Address Resolution Protocol). RARP downloads the IP address to each print server at startup. This method only operates over single network segments. Other Internet-related parameters such as the default router, subnet mask, etc. must be entered manually as RARP only sets the IP address.  
*Default value = No (disabled)*

### IP Address

Specify the IP address for your print server in the format *w.x.y.z*. You should acquire a unique and unused IP address from your Network Administrator in order to prevent conflicts with other network devices.

*Default value = 192.168.0.90*

#### Notes:

- If DHCP, BOOTP or RARP is enabled, your manual settings might be overridden when you perform a restart. To make sure that this will not happen, you are advised to disable BOOTP and RARP when you are setting the IP address manually, DHCP is disabled by default.
- **Important!** If you change the IP address you will lose contact with the print server. You must enter the new IP address of the print server in the location field of your Web browser to continue to configure and manage the print server via the Web browser.

### Subnet Mask

Specify the subnet mask used for determining when the traffic should be sent via a router. This number combined with the IP address identifies on which network the print server is located. The normal class C subnet mask value is usually 255.255.255.0.

*Default value: 0.0.0.0, indicates that all network segments are accessible.*

### Default Router

Specify the IP address for the default router. All traffic directed outside the local network, defined by the subnet mask, is sent to the default router. Any re-routing via other routers is done automatically. The setting 0.0.0.0 indicates that no default router is set. If that is the case, the print server anticipates that there is a router available that automatically senses and redirects the print server's packets to destinations outside the local network segment.

*Default value: 0.0.0.0*

### DNS Server Address

Specify the IP address for the DNS (Domain Name Server). DNS uses NetBIOS names to allow clients to locate resources on TCP/IP networks.

*Default = 0.0.0.0*

### DNS Dynamic Update

Select **Yes** to enable DNS (Domain Name Server). DNS uses NetBIOS names to allow clients to locate resources on TCP/IP networks.

*Default value = No*

### DNS Host name

Specify DNS Host name. This name will be used in all environments as the identifier of your print server.

*Default value = <blank>*

### DNS Domain Name

Specify the name of the domain to which the print server belongs. Domain refers to a set of computers on a network that have been assigned a group name. A domain might contain two or more workgroups.

*Default = <blank>*

### WINS Enabled

Select the appropriate radio button to enable WINS (Windows Internet Name Service) over TCP/IP. WINS uses NetBIOS names to allow Windows-based clients to locate resources on TCP/IP networks.

*Default value = Yes*

### WINS Server Address

Specify the IP address of the primary WINS server. The WINS server is used for identifying computers with host names instead of IP addresses.

*Default value = 0.0.0.0*

### WINS Host Name

Specify the WINS host name, which will be used as the identifier of your print server.

*Default = <blank>*

### Scope ID

Specify the NetBIOS scope to which the print server belongs. The scope ID is a character string value that is appended to the NetBIOS name and used for all NBT communication. The scope ID defines a group of computers that recognizes a registered NetBIOS name. Computers with the same scope ID will be able to hear each others' NetBIOS "traffic" or messages.

*Default value = <empty> which specifies the default scope.*

### SLP enabled

Enable or disable SLP communication to and from the print server.

*Default = Yes*

### SLP scope list

Specify the name of the SLP scope to which the print server belongs. The scope refers to a set of computers on a network that have been assigned a scope name.

*Default value = DEFAULT*

### SNTP Server Address

Specify Time server IP address or Network Name.

*Default = <blank>*

### SNTP update interval

SNTP update interval: The interval the print server shall send a request to the Time Server for a updated time.

*Default = 1 hours*

### Time Zone (Only visible in English firmware version)

Specify the time zone for your print server location.

*Default = GMT*

### Daylight Saving (Only visible in English firmware version)

Select Yes if you have Daylight saving.

*Default = No*

## Support

From the **Support** page you can receive help to resolve any installation or print problems that might occur. If your problems persist, the Support page allows you to produce a Server Report. The Server Report includes the settings of the AXIS 1650, information about your connected printer as well as the current network settings. The Server Report is of great value for support assistance, so please mail, email or fax it to your support channel together with a detailed problem description.

## Troubleshoot and Upgrade

If you cannot successfully install your print server, please try the trouble shooting instructions to solve your installation problems. The trouble shooter is started by clicking the **Trouble Shooting steps** link. If you still cannot print satisfactorily after performing the trouble shooting instructions, please produce a Server Report and contact your local supplier.

## Server Report

A Server Report is a document containing technical information about your print server and the connected printer. This report is of great value for support assistance, so please produce a Server Report and mail, email or fax it to your support channel together with a detailed problem description. Click the Server Report link to send your Server Report and problem description to Axis Communications Support team:

*You must have an e-mail account and an e-mail program set up on your computer. It is also important that you include the entire web page in the mail and not just a link to the page.*

## AXIS Online Services

Click the print server **product page** to receive information about your print server model. The product page, available on the Axis Web Site, offers you up-to-date information, print server manuals, FAQs, software updates and technical support, etc.

## Contact Information

If you need to contact any Axis distributor or local office, please click the **Axis distributor or office** link.

## Statistics

The **Statistics** page displays information about the network traffic to and from the AXIS 1650 as well as information about servers and services that are connected or associated with the AXIS 1650.

**Network Statistics** to display a list of statistical information about the data traffic to and from the print server.

**Network Connections** to display a list of servers and network services that currently are connected to the print server and the status of each connection.

## Print Server Management Using FTP

Having assigned an IP address to your AXIS 1650, as described in 2. *Set the IP Address*, on page 13, you can change the AXIS 1650 parameter settings using the File Transport Protocol (FTP).

### Editing the *config* file

Follow the instructions below to edit the *config* file using FTP:

1. Log in to the AXIS 1650 by typing:  
ftp <host name> or ftp <IP address> in a Command prompt.
2. Enter the user id, the default entry is `root` (if the default password has been changed then it must also be entered).
3. Download the *config* file to your host by typing:  
get config
4. Edit the file using your preferred text editor.
5. Save the *config* file to the AXIS 1650 by typing:  
put config CONFIG

It is important that the destination file is specified in capital letters. Otherwise the edits are temporary and will be lost once the AXIS 1650 has been rebooted.

Example: How to edit the *config* file using FTP from a Command prompt.

```
> ftp npserver
connected to npserver.
220 AXIS 1650 FTP Print Server v1. Nov 1 2004 ready.
Name (npserver:thomas): root
331 User name ok.
230 User logged in
ftp> get config
200 PORT command successful.
150 Opening data connection for config (192,36,253,4,13,223), (mode
ascii).
226 Transfer complete.
8588 bytes received in 0.24 seconds (35.63 kbytes/s)
ftp> put config CONFIG
200 PORT command successful.
150 Opening data connection for CONFIG (192,36,253,4,13,223), (mode
ascii).
226 Transfer complete.
8588 bytes received in 0.45 seconds (19.04 kbytes/s)
ftp> bye
221 Goodbye.
>
```

## FTP Help

By typing `help` in step 3 in the FTP instructions described above, a list of all available files and commands will be displayed.

## Print Server Management Using SNMP

You can use SNMP (Simple Network Management Protocol) for remotely monitoring and configuring the AXIS 1650. All major functions for print servers are supported.

### General Information

SNMP refers to a set of standards for network management, including a protocol, a database structure specification, and a set of data objects. The AXIS 1650 SNMP implementation runs in TCP/IP networks.

The management is handled by NMS (Network Management System) software running on a host on your network. The NMS software communicates with network devices by the means of messages, which are references to one or more objects.

A message can be a question or an instruction to a device, or an alarm triggered by a specific event in a device. Objects are contained in data bases called MIBs (Management Information Base), where MIB-II is a standard database.

The AXIS 1650 supports the following MIBs:

- relevant parts of MIB-II
- relevant parts of the Host Resource MIB
- relevant parts of the Printer MIB
- relevant parts of the CANON-MIB

## Section 5 The Test Button

The test button is located on the front right hand side of the print server and is used to perform a Factory Default:

1. Remove the external power supply to switch off the print server.
2. Press and hold down the test button, while you reconnect the external power supply.
3. Continue to hold down the test button until the network indicator remains constantly lit. This should take about 20 seconds.
4. Restart the print server by disconnecting and reconnecting the external power supply .

### Important:

- A factory default will reset all print server parameters and settings to their default values except Node address (NODE\_ADDR.)
- The IP address (INT\_ADDR.) will be reset to default **192.168.0.90**

If the AXIS 1650 is connected to a **BubbleJet** printer, the test button can be used for the following operations:

- **Print a Test Page**  
Press the test button **once** to print a test page. The test page contains basic information about the print server. It is recommended that you print a test page every time you connect the print server to a printer
- **Perform a Factory Default**  
See description above.

## Section 6 Upgrading the Firmware

The print server's *firmware*\* is stored in its Flash memory. This memory retains data content even after the power is removed. Flash memory allows data to be erased and re-written, which is why you can install firmware updates in your print server as they become available, without having to replace any parts. New firmware can simply be loaded into the AXIS 1650 over the network.

\* Firmware is internal print server software that determines its functionality.

You can obtain all print server firmware free of charge from the following locations:

- [www.axis.com](http://www.axis.com)
- your local dealer

Caution!

- Be careful not to interrupt the file transfer. If the transfer is interrupted, the print server may have to be re-initialized by your dealer.
- Before upgrading the print server, ensure that it is not printing jobs. You have to wait until the print job is finished before you can proceed.

## Upgrading using FTP

- To upgrade over the network using FTP you will need a file with the new print server firmware. The name of this file is in the form `product_version.bin`.
- The print server must have a valid IP address.

*This example uses these sample values:*

- Print server model: AXIS 1650
  - IP address of print server: 10.13.4.105
  - New firmware version name: 1650\_1\_00.bin
  - Location of firmware and upgrade procedure: C:\Axis  
(Create a new directory named e.g. 'Axis' on your hard drive and download the firmware to that location).
1. From [www.axis.com/techsup/firmware](http://www.axis.com/techsup/firmware), download the firmware and save it to a new directory on your computer, e.g. **C:\ Axis**
  2. Open a command prompt from Start => Run. Type **cmd** in the Run Window and click OK.
  3. The DOS Command Prompt window will open. Make sure you are working from the c: directory (type **c:** and press **Enter**).
  4. Type **cd Axis**
  5. Type **dir** and press Enter. The Axis directory you have created will display a list of all files.
  6. Connect to the print server using ftp: Type **ftp 10.13.4.105** (this example uses print server IP address 10.13.4.105)
  7. Enter the user name, the default user is **root** (if the default password has been changed then it must also be entered). Press **Enter**.
  8. Change to binary transfer mode: type **bin** and press **Enter**.
  9. Type **hash** and press **Enter**.
  10. Use the 'put' command to upload the upgrade file to the flash location:  
Type **put 1650\_1\_00.bin FLASH**. A stream of hash marks will appear.
  11. You will receive a message stating "Transfer complete. Flash programming finished OK. "
  12. The print server will restart in five seconds running the new software.



## Appendix A      Enabling Unicast Network Communication

**IMPORTANT!** All network configuration must be performed by the network administrator!

AXIS 1610 and AXIS 1611 do not support the Unicast mode.

AXIS CAPT Print Monitor uses broadcast communication, so that status information from the print server can be shared between several users without elevating network traffic.

Broadcast communication is used by default in the print server.

In some networks where broadcast communication isn't preferred, unicast communication can be used, which will also increase the network load.

To enable unicast communication, some settings must be configured in the AXIS 1650 and in the AXIS Print Monitor during the software installation.

**Follow these steps to enable unicast network communication:**

1. Open a command prompt and change to a directory where you can store the configuration file by typing **C:/<any directory>** and press Enter.
2. Log in to the AXIS 1650 with the command:  
**ftp <IP address>**  
where <IP address> is the IP address of your AXIS 1650.
3. You will be prompted for a user id:  
default user id = **root** (if the default password has been changed then it must also be entered)
4. To access the configuration file, type: **get config**
5. Next go to the C: directory on your computer and locate the file named **config**.

- Open the config file using any text editor:

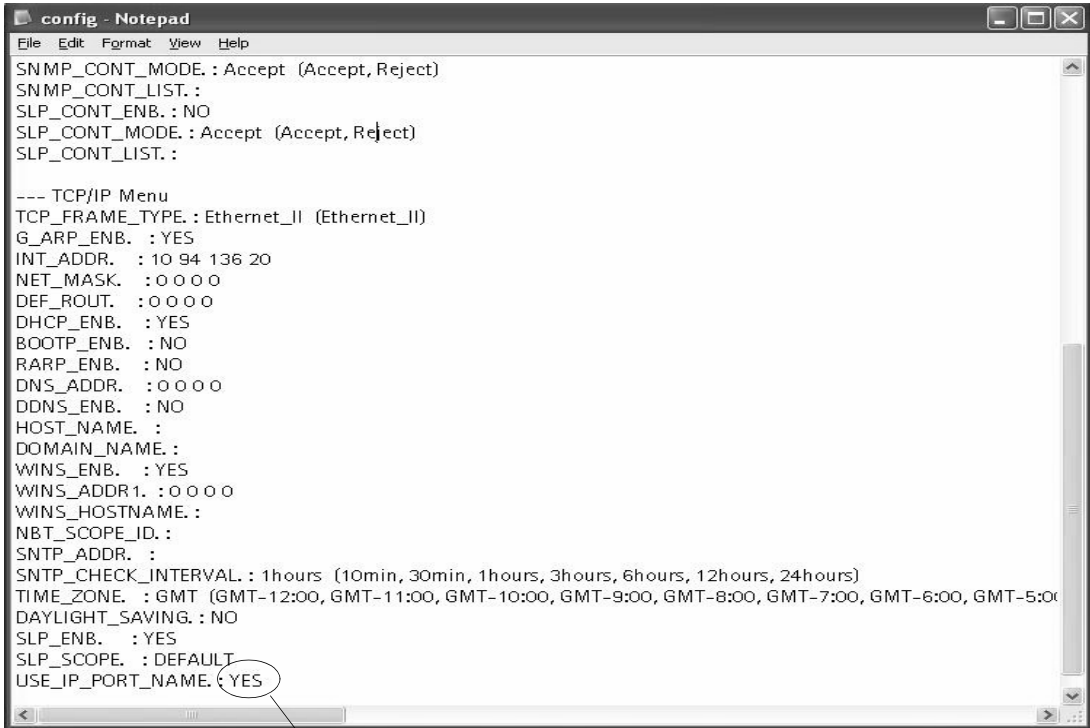

```

config - Notepad
File Edit Format View Help
SNMP_CONT_MODE : Accept (Accept, Reject)
SNMP_CONT_LIST. :
SLP_CONT_ENB. : NO
SLP_CONT_MODE. : Accept (Accept, Reject)
SLP_CONT_LIST. :

--- TCP/IP Menu
TCP_FRAME_TYPE. : Ethernet_II (Ethernet_II)
G_ARP_ENB. : YES
INT_ADDR. : 10 94 136 20
NET_MASK. : 0 0 0 0
DEF_ROUT. : 0 0 0 0
DHCP_ENB. : YES
BOOTP_ENB. : NO
RARP_ENB. : NO
DNS_ADDR. : 0 0 0 0
DDNS_ENB. : NO
HOST_NAME. :
DOMAIN_NAME. :
WINS_ENB. : YES
WINS_ADDR 1. : 0 0 0 0
WINS_HOSTNAME. :
NBT_SCOPE_ID. :
SNTP_ADDR. :
SNTP_CHECK_INTERVAL. : 1hours (10min, 30min, 1hours, 3hours, 6hours, 12hours, 24hours)
TIME_ZONE. : GMT (GMT-12:00, GMT-11:00, GMT-10:00, GMT-9:00, GMT-8:00, GMT-7:00, GMT-6:00, GMT-5:00)
DAYLIGHT_SAVING. : NO
SLP_ENB. : YES
SLP_SCOPE. : DEFAULT
USE_IP_PORT_NAME. : YES

```

Make sure this parameter is set to YES.

- Locate the parameter named **USE\_IP\_PORT\_NAME**:  
type **YES**
- Once the editing is complete, save the file as **config**
- In the Command prompt window, upload the configuration file to the AXIS 1650 by typing  
**put config CONFIG**
- To exit FTP, type  
**quit**

**Note:** This will also change the **Print Server Name** parameter so that it is based on the print server's IP address, with "\_" replacing the "." in the address.

*Example: If the print server's IP address is 192.168.3.191 the Print Server Name parameter will be changed to 192\_168\_3\_191.*

It is important that the destination file is specified in capital letters. Otherwise the edits are temporary and will be lost once the AXIS 1650 has been rebooted.

11. Install AXIS CAPT Print Monitor software on your workstation. The software is available on the AXIS 1650 CD and on [www.axis.com](http://www.axis.com). Click your way through the program.
12. During the software setup, you will reach the **Set the Unicast Communication Mode** screen, check the **Enable unicast** check-box.



13. Click **Next** and **Finish** to finish the installation.
14. **Windows XP/Server 2003:**  
Go to **Start | Printers and Faxes** and click the **Add a Printer** icon to start the Add Printer Wizard. (Windows XP Home Edition: **Start | Control Panel | Printers and Faxes | Add a Printer**). Click **Next**.  
**Windows 2000:**  
Go to **Start | Settings | Printers** and click the **Add Printer** icon to start the Add Printer Wizard. Click **Next**.
15. Select **Local Printer attached to this computer**. Make sure the **Automatically detect and install my Plug and Play printer** check box is not checked. Click **Next**.

- Click the **Create a new port** radio-button and select **AXIS CAPT Port**. Click **Next**.

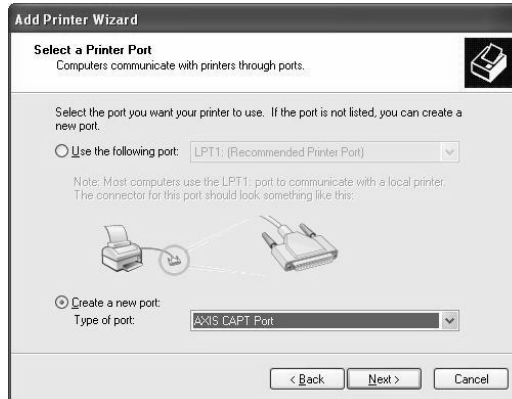

- A pop-up window will appear. Enter the IP address of the AXIS 1650.
- Select **Manufacturer and Printer** from the driver list. Click **Next**.
- Choose whether you want to keep the existing driver or to replace it. If you already have the printer's driver installed, you will be asked whether to keep it or to replace it.
- Click **Next**. Supply a name for the printer and choose whether you want to make it your default printer. Click **Next**.
- Choose whether you want to share the printer with other network users, print a test page, etc. Select the appropriate radio button and click **Next** and **Finish**.
- Print a test page to verify. You have now completed the installation.

## Appendix B Internet Connection Firewall in Windows XP SP2

If you have upgraded to Windows XP SP2, you need to open UDP port 10260 in the Internet Connection Firewall when using Broadcast communication. For Unicast communication, the firewall can remain closed.

UDP port 10260 is opened automatically in Internet Connection Firewall, if allowed during the installation of AXIS CAPT Print Monitor in Windows XP/2003, see *Windows Installation*, on page 22.

To open the Internet Connection Firewall:

1. Go to Start | Control Panel | Security Center.
2. Select Firewall:



3. Make sure **On** is selected. "Don't allow exceptions" and "Off" must be unchecked!



4. Click **Exceptions** and highlight **AXIS CAPT Port**.



5. Click **OK**.

**Note:**

If you accidentally delete the AXIS CAPT Port and want to recreate it, go to **Exceptions | Add Port** and configure the port.

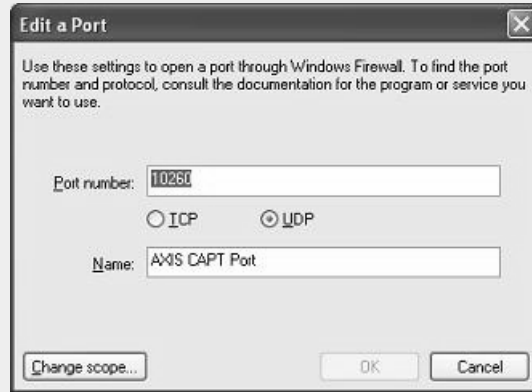

# Technical Specifications

## Supported Printers

AXIS 1650 is developed to network Canon printers and multifunctional products. AXIS 1650 supports host-based printing methods such as Canon Advanced Printing Technology, Canon Advanced Raster Printing System and other printer types such as Canon BubbleJet.

**IMPORTANT:** Printers from other manufacturers than Canon are not supported.

## Supported Systems

### Microsoft Windows:

Windows 98, Windows 2000, Windows Me, Windows XP, Windows Server 2003.  
Print Methods: LPR, Raw TCP, CAPT over TCP/IP in Microsoft Windows

### WWW:

Netscape Communicator 4.7 and above, Internet Explorer 4.0 and above.

## Supported Protocols

Windows: TCP/IP, WINS.

### TCP/IP:

LPD, FTP, BOOTP, ARP, RARP, DHCP, ICMP, IGMP, IP, TCP, UDP, HTTP, SLP, SNMP, Raw TCP, DNS, DDNS.

## Network Management

Print server/job/printer status presentation and management via standard web browser or ftp.

## Supported Languages

English and Japanese.

## Logical Connection

Supports NWay that provides auto-detection of network speed. Use Ethernet II frame type, full duplex.

## Wired Network Attachments

RJ-45 connector (Category 5 shielded twisted pair cable) for 10baseT Ethernet or 100base TX Fast Ethernet.

## Printer Ports

- One Low and -Full speed USB 1.1 port, and works with USB v 2.0 (Low-Speed and Full-Speed).  
The USB cable shipped with the product supports Low-Speed and Full-Speed. *Hi-Speed is not supported.*
- One high-speed IEEE 1284 compatible parallel port.

## Power Consumption

Maximum 5.6 W. Power provided by Power Adapter type PS-H: 5.1V DC 2000 mA

## Dimensions

Height x Width x Depth

1.1in (29 mm), 2.4in (62 mm), 4.6in (117 mm)

Weight

0.18lb (81g)

## Environmental

Temperature:

40 - 105 °F (5 - 40 °C)

## Approvals

EMC:

EN 55 024:1998

EN 55 022:1998 + A1 (CISPR 22:1997 + A1) Class B

EN 61000-3-2:2000

EN 61000-3-3:1995+A1

VCCI:2002 Class B ITE (CISPR 22:1997 + A1:2000, Class B

C-tick AS/NZS 3548

FCC part 15, subpart B, Class B, demonstrated by compliance with EN 55022:1998 (CISPR 22:1997) Class B.

## Safety

EN 60950, approved power supplies for all countries.

## Hardware

32-bit 100 MHz AXIS ETRAX 100LX RISC Controller, 2 MB Flash memory, 8 MB RAM.

## Front Panel

2 LED indicators for Power and Network.

Test button for performing Factory Default

All specifications are subject to change without prior notice.

# Index

## A

- Adhesive Clip 12
- Adhesive Holder 12
- Admin 36
- Assistance 6

## B

- BOOTP 44
- Broadcast 62
- BSD 17
- BubbleJet 54

## C

- Canon Advanced Printing Technology 1, 8, 38, 45, 65
- Canon Advanced Raster Printing System 1, 8, 38, 65
- Canon BubbleJet 1, 8, 65
- Configuration methods
  - FTP 51
  - SNMP 53
  - Web browser 37
- Configure Port 34

## D

- Daylight Saving 49
- default IP address 192.168.0.90 14
- default values 40
- DHCP scope 21

## F

- firmware 55
- firmware version 5
- Flash memory 55
- FTP 51

## H

- Host Name 21

**I**

- IEEE 1284 parallel port 10, 66
- Installing printer Ports
  - Windows 2000 23, 29
- Installing printer ports
  - Windows 2000,XP, 2003 23
  - Windows 98, Me 29
- Internet Connection Firewall 62
- IP Address
  - Automatic Assignment Methods 21
  - Manual Assignment Methods 21
  - Setting, using ARP 16, 17
  - Setting, using AXIS IP JumpStarter 14

**L**

- Label, backside 11
- Language 41
- License Agreement 23
- Local Printer 30
- LPR Settings 34

**N**

- Network Settings 45

**P**

- Parameter List 44
- password 37
- peer-to-peer printing 22
- Print Jobs 39, 45
- Print Server Name 38
- Print server name 21
- Printing
  - Test Page 54

**Q**

- Queue Name 34

**R**

Remote Printer Port 31

Restart 44

Root Password 41

**S**

Serial Number 39, 44

Setting the Internet address

    ARP 17

SLP enabled 48

SLP restriction enabled 42

SLP restriction IP address list 43

SLP restriction mode 43

SNMP 53

SNMP access enabled 41

SNMP restriction enabled 42

SNMP restriction IP address list 43

SNMP restriction mode 43

SNTP Server Address 48

SNTP update interval 49

Software Default 44

Support 6, 49

Supported Printers 65

Supported printers 8

System Comment 41

System Contact

    41

System Location 38, 41

System Manager Telephone Nbr 41

System Name 40

**T**

TCP restriction enabled

    42

TCP restriction IP address list

    42

TCP restriction mode

42

Technical Assistance 6

Test Button 54

Test Page 54

TFTP 44

This Print Server 40

Time Zone 49

two connected printers 10

## U

UDP port 10260 62

UNIX 17

User 36, 37

## W

Installing printer ports 23, 29, 61

Windows XP 23

WINS 21

## Z

z 34